



Nichiyu explosion-proof forklift trucks comply with the **de2G4** grade of the explosion-proof standard of the Japanese Labor Safety and Health Law, and can be used in Zone 2 hazardous areas.

d Flame-proof construction

(Applicable to motors, control units and switch boxes)
This indicates fully enclosed construction. The enclosure can withstand the force of a gas vapor explosion occurring within it. It also prevents any sparks from contacting an external explosive gas.

2 Explosion class

Explosion classes are ranked as class 1, 2 and 3 in order of increasing risk of gas explosion. The larger the number, the greater the risk of an explosion.

e Increased Safety construction

(Applicable to battery and horn)
This type of construction features increased insulation and security in order to protect against the dangers of increased temperature and damage from an external force.

G4 Ignition group

Explosive gases are classified into five categories according to ignitability. The higher the category number, the lower the ignition temperature and the greater the risk of explosion.

Classification of Explosive Substances by Ignition Group and Explosion Class

Explosion class	Ignition group	G1	G2	G3	G4	G5
1	Acetone Ammonia Carbon monoxide Ethane Acetic acid Ethylacetate	Toluene Propane Benzene Methanol Methane	Ethanol Amylacetate-iso 1-Butanol Butane Acetic anhydride	Gasoline Hexane	Acetaldehyde Ethyl ether	
		Coal gas	Ethylene Ethylene oxide			
3	Water gas Hydrogen	Acetylene				Carbon disulfide

Accessories for higher operational efficiency

Equipment	Model	FBR(A) 10H-13H	FBR(A) 14-18	FBR(A) 20-30
Electric power steering	S	S	S	S
Head lamps	O	O	O	O
Turn signal lamps	O	O	O	O*
Electric horn	S	S	S	S
Back up alarm	O	O	O	O
Chime	O	O	O	O
Revolving light	O	O	O	O
Hour meter	S	S	S	S
Battery indicator	S	S	S	S
Lift limit switch	O	O	O	O

S : Standard
O : Option
*Standard for FBR25/30 FBR25/30

Standard specifications

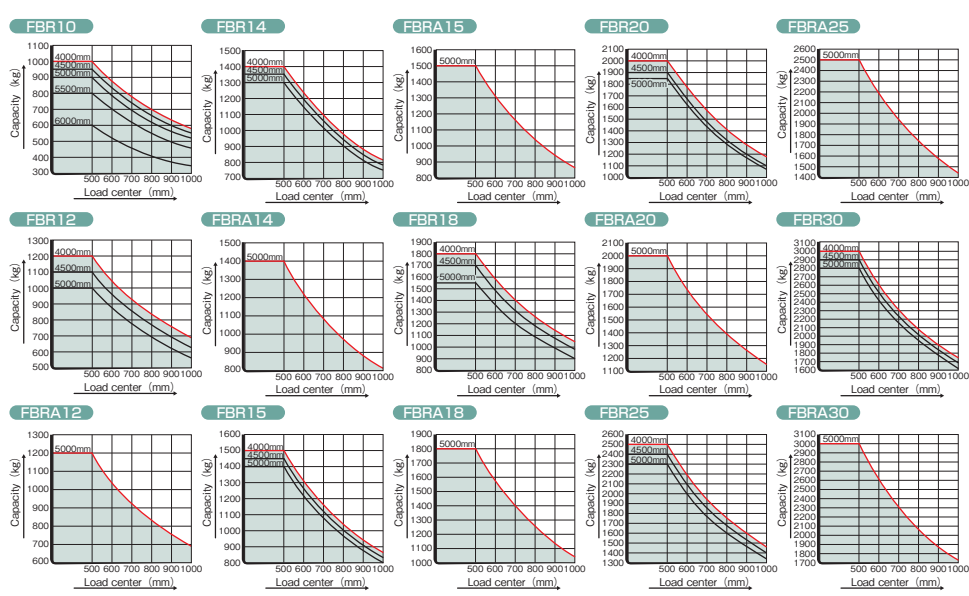
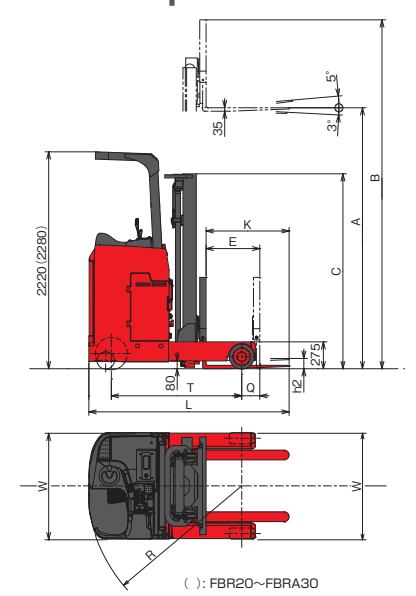

Models		FBR-E80 series														
		FBR10	FBR12	FBR12	FBR14	FBR14	FBR15	FBR15	FBR18	FBR18	FBR20	FBR20	FBR25	FBR25	FBR30	FBR30
Capacity	kg	1000	1200	1200	1400	1400	1500	1500	1800	1800	2000	2000	2500	2500	3000	3000
Lift height	A mm	3000	3000	4000	3000	4000	3000	4000	3000	4000	3000	4000	3000	4000	3000	4000
Free lift	h2 mm	105		400	105	400	105	400	110	405	120	400	120	400	125	405
Lifting speed	Laden	340		320		310		300		260		250		210		
	Unladen	540		540		540		450		390						
Traveling speed	Laden	9.5		9.5		10.0		9.5		9.0						
	Unladen	10.5		10.5		11.5		11.0								
Minimum turning radius	R mm	1340	1450	1510	1520	1580	1760	1810	1785	1955	2020	2050	2550	2050	2550	
Reach stroke	E mm	380	500	560	490	550	730	635	805	870	835	935				
Overall length	L mm	1960		2050		2125		2175		2245		2310		2410		
	W mm	1090		1090		1190										
Overall height	C mm	1995	2495	1995	2495	1995	2495	1995	2495	2050	2550	2050	2550	2050	2550	
	B mm	3900		4900		3900		4900		3900		4900		3900		4900
Fork length	K mm	850		850		920		920								
Wheelbase	T mm	1085	1205	1265	1275	1335	1515	1515	1685	1755	1785	1985				
Front overhang	Q mm	175		185		190		195		190						
Service weight	kg	2050	2140	2240	2200	2300	2260	2490	2410	2770	2930	3090	3020	3190	3360	3980
Drive	mm	φ254×114 / Urethane		φ254×114 / Urethane		φ267×114 / Urethane		φ267×114 / Urethane		φ267×135 / Urethane						
	mm	φ330×145 / Rubber		φ330×145 / Rubber		φ380×165 / Rubber		φ204×76 / Rubber								
Casters	mm	φ178×73 / Rubber		φ178×73 / Rubber		φ204×76 / Rubber										
Control system		Inverter														
Motors	kW	Travel[35%]: 4.5 / Hydraulic[25%]: 8.5 / Power steering[35%]: 0.39														
Voltage	V	48		48		48										
	Capacity	201	210	280	320	320	370	370								
Option		240	280	320	370	370	-	-								
Charger	Capacity	3 φ 200V Automatic stationary charger														
	kVA	3.8		3.8		4.7		4.7		6.5						

* The right load wheel uses a conductive tire.
* [] : Operating Duty = $\frac{\text{Operating time of motor}}{\text{Time of one operating cycle}} \times 100(\%)$

All specifications have been determined according to manufacturer's terms and conditions. Specifications are subject to change without notice in the interests of product improvement.



www.nichiyuforklift.com.sg
©2018 by MLAP. All Rights Reserved. All registered trademarks are the property of their respective owners. Printed in Singapore.
FNCY0005 (09/18)



**ELECTRIC FORKLIFT
STAND-ON REACH TRUCKS
PLATTER**

Explosion-proof Type



Committed to safety and efficiency in addition to operator comfort, explosion proof PLATTER provides reliable operation in Zone 2 hazardous sites.

Since developing Japan's first explosion-proof truck in 1965, Nichiyu has excelled at offering a varied selection of explosion-proof models. We now offer enhanced safety as well as even greater operator comfort. Our wide and varied selection of 15 models offers you a choice of trucks that will dramatically improve your work efficiency.

PLATTER

Explosion-proof type
1.0-3.0t



Photo: FBR15-E80 (with option)

FBR-E80 Lineup

Capacity	1.0t	1.2t	1.4t	1.5t	1.8t	2.0t	2.5t	3.0t
FBR 3m Mast	FBR10	FBR12	FBR14	FBR15	FBR18	FBR20	FBR25	FBR30
FBRA 4m Mast	FBRA12	FBRA14	FBRA15	FBRA18	FBRA20	FBRA25	FBRA30	



More advanced technology in reliable explosion-proof construction



Flame-proof construction

Flame-proof construction is incorporated in all electric devices, including the motor and controller, which are the heart of PLATTER.



Traction / Hydraulic motor

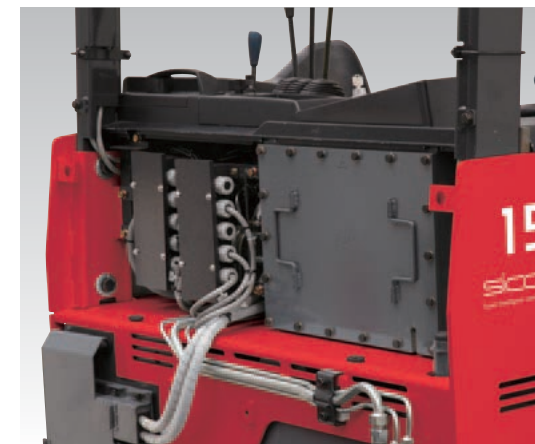

Controller

Increased safety construction

The battery and electric horn of this vehicle are designed and constructed with increased safety in mind. This protects them from damage by outside force and offers increased electrical insulation. Moreover, the truck also incorporates a new charging plug that eliminates the inconvenience of disconnecting the battery plug when recharging.



Battery

Explosion-proof accessories

Optional accessories such as head lamps or turn signal lamps are also explosion-proof.



Turn signal lamps

Newly designed control panel maximizes operator's performance

Super Intelligent Control System



Two CPUs process the traveling system and hydraulic system independently. Another main CPU manages all other information. The main CPU is connected to the display and handles all operation settings, function settings and indicator settings. The result is comfortable, stress-free operation in a variety of environments.

Newly designed equipment layout for advanced ease of use

The horn, switch and levers are oriented to ensure the most appropriate operation.



Transmissive LCD

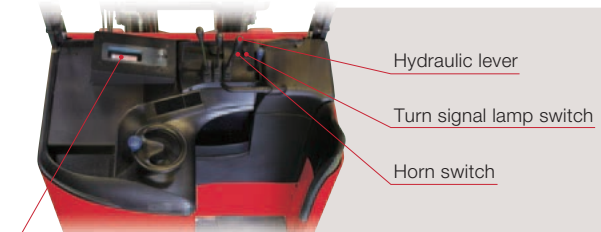

Hydraulic lever

Turn signal lamp switch

Horn switch

Comfortable operator's compartment enables stress-free operation

By optimizing the layout of internal components, the step height was reduced, contributing to easier operator entry.

Floor height	FBR15
Previous model	PLATTER
	315mm → 265mm



265mm

Glove compartment and flat top panel for documents

Platter is equipped with a glove compartment and a flat top panel that accepts magnets for simplified document storage.

The operator can maintain an ideal posture while manipulating the steering wheel and the travel / hydraulic levers

The steering wheel and the levers are oriented to ensure the most comfortable posture during operation.

Large waist pad for reduced operator fatigue

The enlarged waist pad features soft touch materials and helps the operator maintain posture.

Hand grip assists easy ingress and egress



Efficiency and safety, with advanced reliability and easier serviceability

AC controlled IPM traction and hydraulic motors yield high efficiency.

An oil damper improves stability when turning.

Temperature sensors incorporated in the motors monitor and prevent overheating.

After temporarily stopping on an incline and releasing the brake, you will descend only at very slow speed until you apply the accelerator and easily continue on your way.

(Safety Cruise)

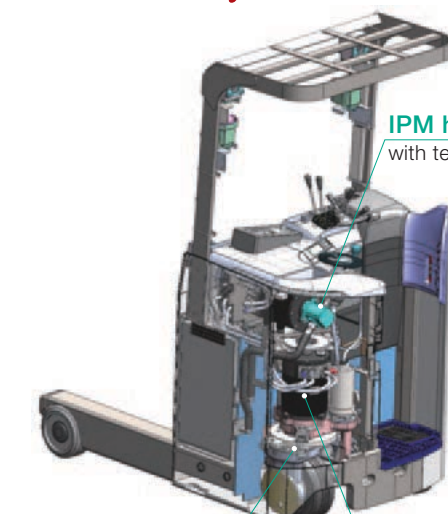

IPM hydraulic motor with temperature sensor

Oil damper

IPM traction motor with temperature sensor